

ISO VIEW
SCALE 5/1

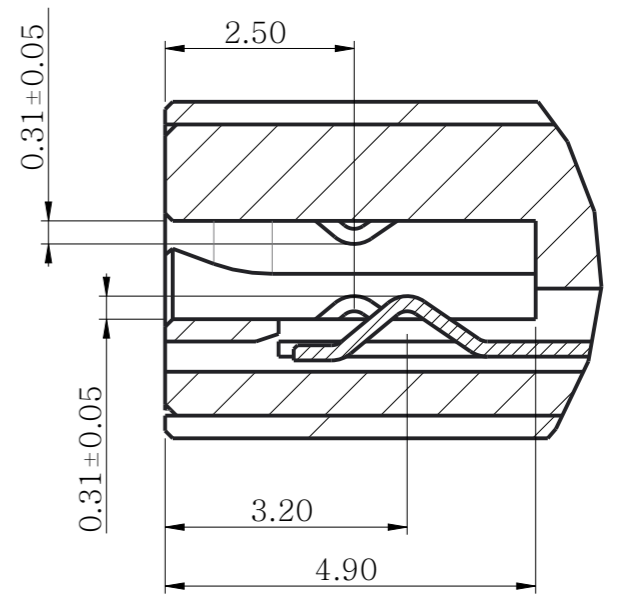

DETAIL A
SCALE 10/1

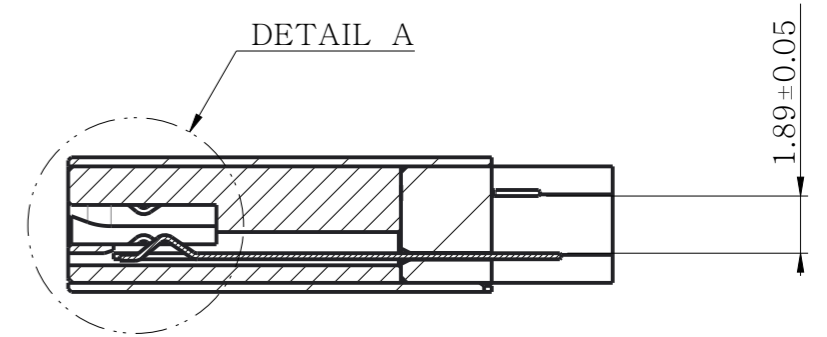
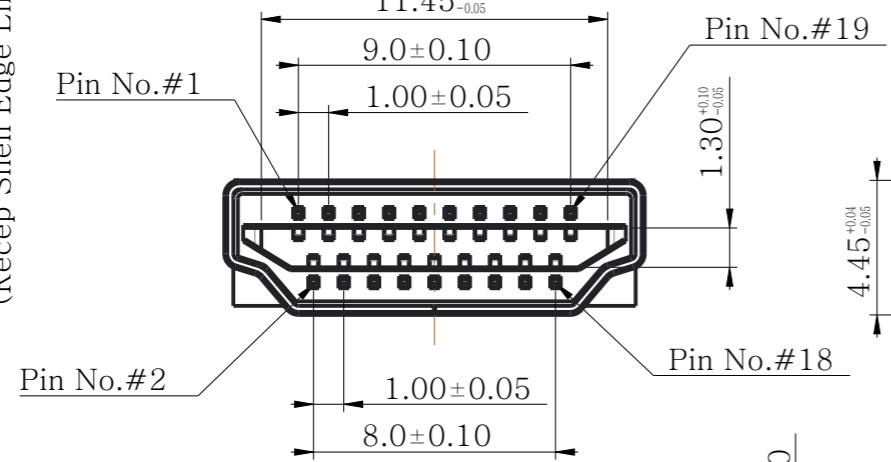

SECTION A-A

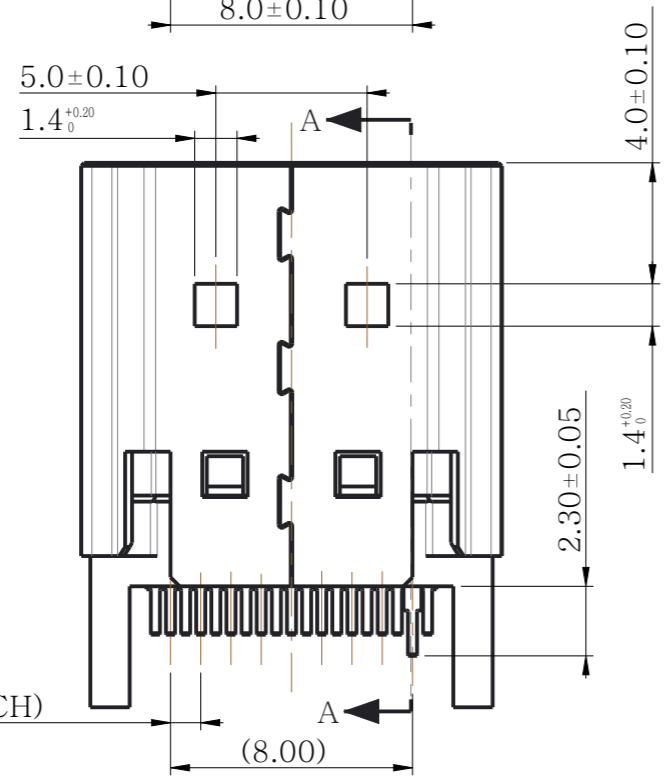

4	Metal Shell	SUS	-	Ni Plating	1	T=0.30
3	Guide	Thermoplastic	Black	-	1	UL94V-0
2	Terminal	COPPER ALLOY	-	Au over Ni Plating	19	T=0.15
1	Housing	Thermoplastic	Black	-	1	UL94V-0
No	Part Name	Material	Color	Finish	Q'ty	Remark

ISSUE MARK

		MATERIAL		SEE TABLE	KIEP ELECTRIC	
		FINISH		SEE TABLE	KIEP TERMINAL CO., LTD.	
		WIRE RANGE		CLASS HDMI R2.1 Plug		
		INSULATION		TYPE 19P		
NEW RELEASE	JMC LJH BWC 15.06.29	TOLERANCE		X±0.1	SCALE	PART NO. K500125-19
L TR REVISION RECORD		DR. CHK. APP. DATE		X.X±0.08	4/1	
DR. MC.JEON 20150629		CHK. JH.LEE 20150629		X.XX±0.05	PART_NAME	
CHK.		APP. WC.BAEK 20150629		HDMI R2.1 PLUG 19P		