

- \* NOTE \*
- 1.TOLERANCE : ±0.2 , ANGLE ±3°
  - 2.CONPLANARITY : 0.1 MAX
  - 3.PART CODE

MG 6 4 4 5 0 6

PART NO.  
RECEPTACLE ASS'Y

- 4."6 Hazardous substance in parts(Lead,Mercury,Cadmium Hexavalent Chromium,PBBs,PBDEs)shall not exceed the maximum permissible concentration prescribed under EU ELV Directive & RoHS Regulation."
- 5.No Twist
- 6.Spec : ES91500-03
- 7.Solder : Reflow Solder Only(Surface mount)

PIN NO.	A	B	C
30	11.2	21.0	18.0
40	15.2	25.0	22.0
50	19.2	29.0	26.0
60	23.2	33.0	30.0
70	27.2	37.0	34.0
80	31.2	41.0	38.0
90	35.2	45.0	42.0
100	39.2	49.0	46.0
110	43.2	53.0	50.0
120	47.2	57.0	54.0

NO.	PART NAME	MATERIAL	FINISH	Q'TC
4	RECEP HOUSING COVER 40P	Polyamide	UL94-V0, BLACK	1
3	METAL-FITTING	Copper Alloy	Ni1.27~3um+Sn2-5um MAX	2
2	RECEP TERMINAL 40PIN	Copper Alloy	Ni1.27~3um+Au 0.1um MAX(Contact) & Au0.03um MIN(Lead)	40
1	RECEP HOUSING 40P	Polyamide	UL94-V0, BLACK	1

MATERIAL	FINISH	WIRE RANGE	INSULATION	SCALE	PART NO.
-	-	-	-	1/1	MG644506
<b>KET KOREA ELECTRIC (ENGINEERED) TERMINAL CO., LTD.</b> CLASS BOARD TO BOARD TYPE FLOATING P=0.8mm PART NAME B TO B RECEP 40P H7.05 ASS'Y					1

DESIGN REVISION NO. 1

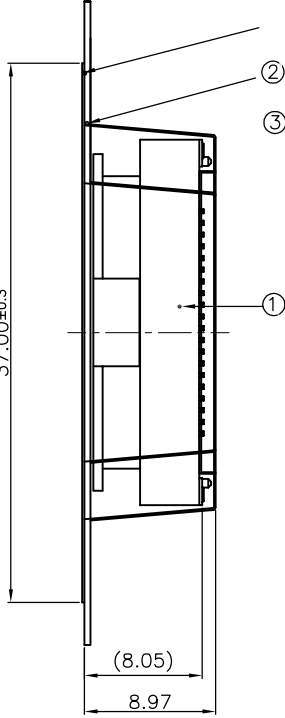
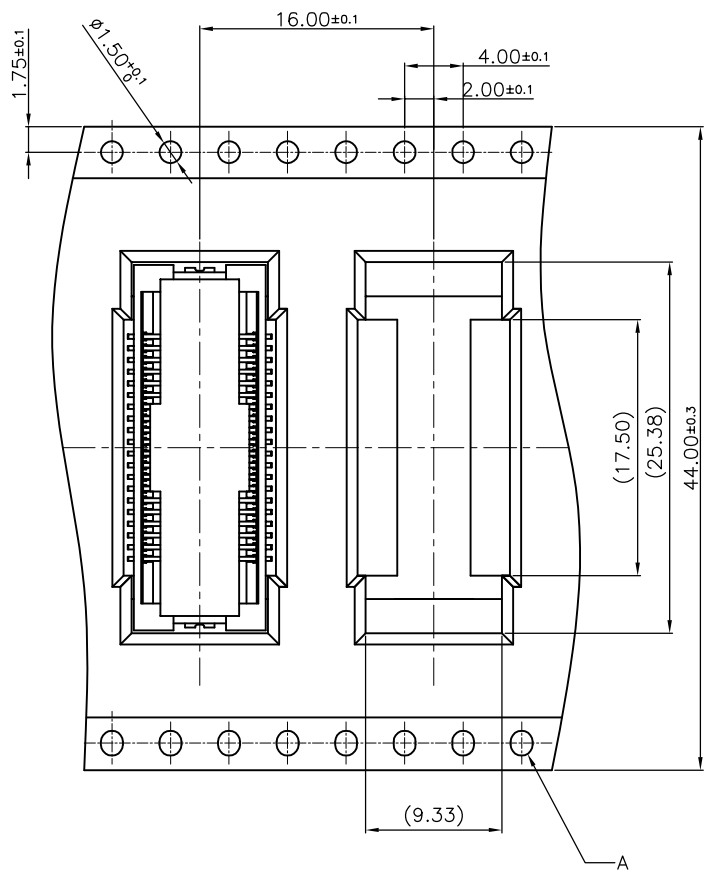

- NOTE -
- 1.NUMBER OF CONNECTOR:700PCS/REEL
  - 2.LEAD TAPE LENGTH(mm)
  - 3.PEELING OFF FORCE OF TOP TAPE: 0.1N - 0.7N(10.2 - 71.4gf)  
PEELING OFF SPEED: 300mm/Min

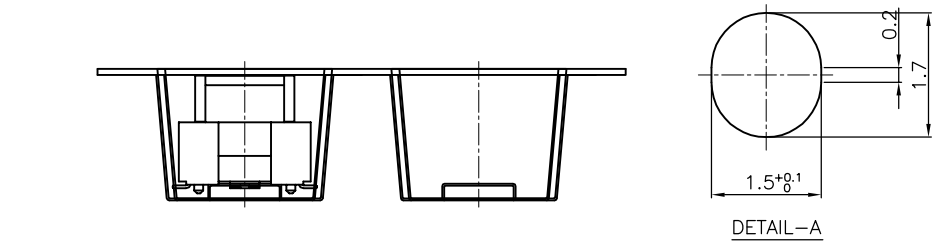
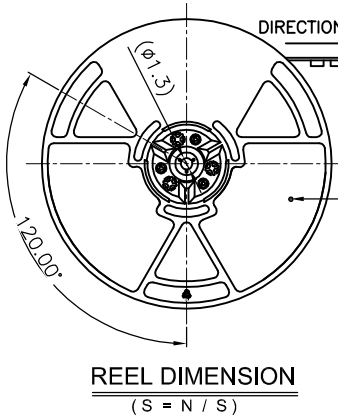
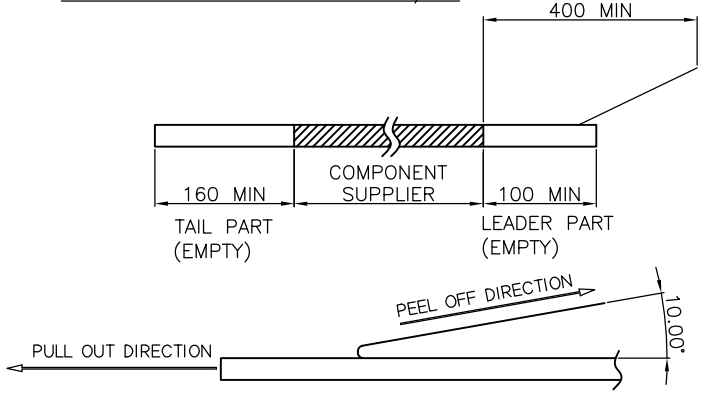

TOOL NO.	ISSUE MARK
300002	

NO.	NAME	MATERIAL	FINISH	PART NO.	Q'TC
4	REEL	PS	BLACK & BLUE	-	1
3	COVER TAPE	PET	-	-	-
2	CARRIER TAPE	PET 0.4t	-	-	-
1	40P RECEP ASS'Y	-	-	MG644506	700

MATERIAL	FINISH	WIRE RANGE	INSULATION	SCALE	PART NO.
-	-	-	-	1/1	P300002
<b>KET KOREA ELECTRIC (ENGINEERED) TERMINAL CO., LTD.</b> CLASS BOARD TO BOARD TYPE FLOATING P=0.8mm PART NAME B TO B RECEP 40P TAPING PRODUCT					1

DESIGN REVISION NO. 1