

- NOTE -
 1. TOLERANCE: ±0.2, ANGLE ±3°
 2. CONPLANARITY: 0.1 MAX
 3. PART CODE

MG 6 4 4 7 6 0

PART NO.
RECEPTACLE ASS'Y

4. "6 hazardous substances in parts (Lead, Mercury, Cadmium, Hexavalent Chromium, PBBs, PBDEs) shall not exceed the maximum permissible concentration prescribed under EU ELV Directive & RoHS Regulation."
 5. No Twist
 6. Spec : ES91500-03
 7. Solder : Reflow Solder Only(Surface mount)

PIN NO.	A	B	C
30	11.2	24.0	18.0
40	15.2	25.0	22.0
50	19.2	29.0	26.0
60	23.2	33.0	30.0
70	27.2	37.0	34.0
80	31.2	41.0	38.0
90	35.2	45.0	42.0
100	39.2	49.0	46.0
110	43.2	53.0	50.0
120	47.2	57.0	54.0

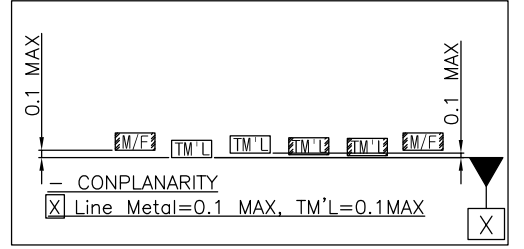
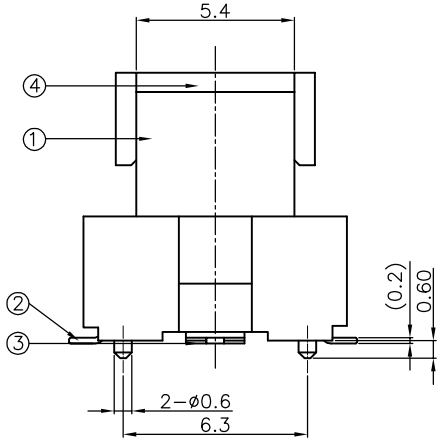
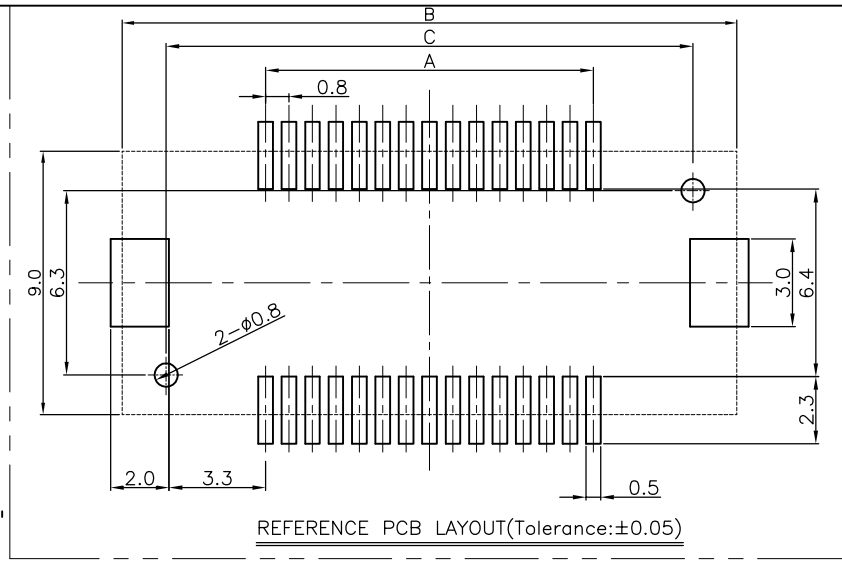

DIE NO ISSUE MARK

NO.	NAME	MATERIAL	FINISH	Q'TC
4	RECEP HOUSING COVER 40P	Polyamide	UL94-V0, BLACK	1
3	METAL-FITTING	Copper Alloy	Ni1.27~3um+Sn2-5um MAX	2
2	RECEP TERMINAL 40PIN	Copper Alloy	Ni1.27~3um+Au 0.1um MAX(Contact) & Au0.03um MIN(Lead)	40
1	RECEP HOUSING 40P	Polyamide	UL94-V0, BLACK	1

MATERIAL	FINISH	WIRE RANGE	INSULATION	SCALE	PART NO.
-	-	-	-	1/1	MG644760

LTR	REVISION RECORD	DR	CHK	APP	DATE	TOLERANCE EXCEPT AS NOTED	SCALE	PART NAME
		Um.Y.H'		B.W.C	09.04.01	-	1/1	B TO B RECEP 40P H8.6 ASS'Y

DESIGN REVISION NO. 1

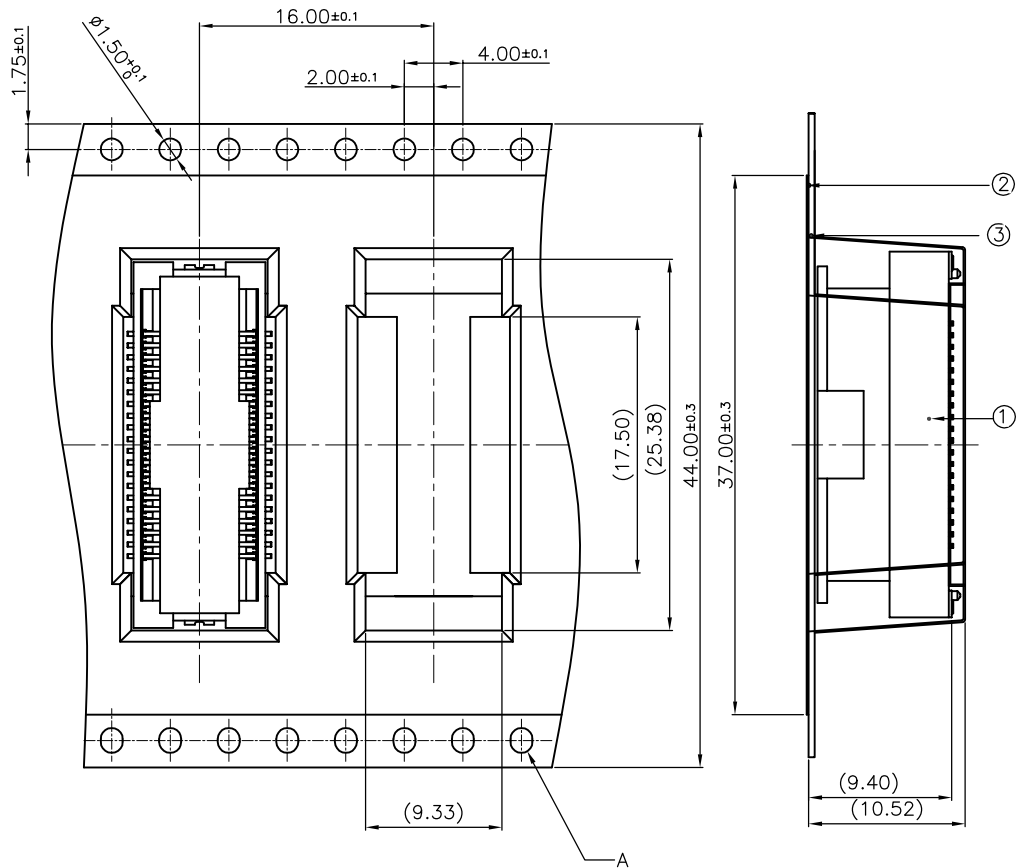

- NOTE -
 1. NUMBER OF CONNECTOR: 500PCS/REEL
 2. LEAD TAPE LENGTH(mm)
 3. PEELING OFF FORCE OF TOP TAPE: 0.1N - 0.7N(10.2 - 71.4gf)
 PEELING OFF SPEED: 300mm/Min

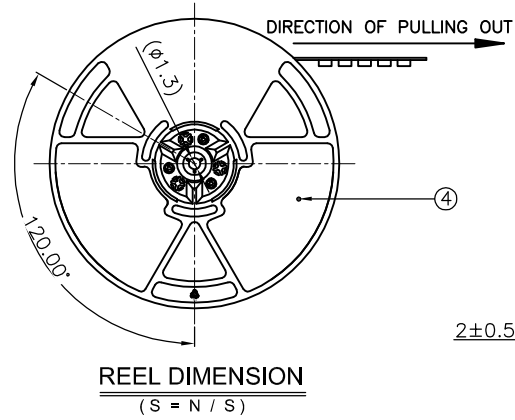
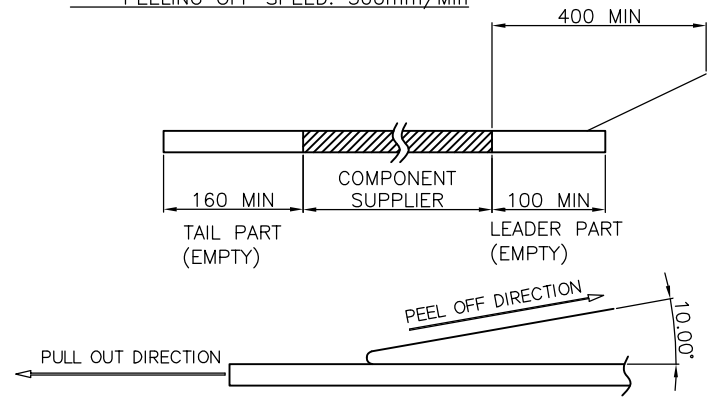

TOOL NO ISSUE MARK

NO.	NAME	MATERIAL	FINISH	PART NO.	Q'TC
4	REEL	PS	BLACK & BLUE	-	1
3	COVER TAPE	PET	-	-	-
2	CARRIER TAPE	PET 0.4t	-	-	-
1	40P RECEP ASS'Y	-	-	MG644760	500

MATERIAL	FINISH	WIRE RANGE	INSULATION	SCALE	PART NO.
-	-	-	-	1/1	P300004

LTR	REVISION RECORD	DR	CHK	APP	DATE	TOLERANCE EXCEPT AS NOTED	SCALE	PART NAME
		Um.Y.H'		B.W.C	09.04.11	±0.3	1/1	B TO B RECEP 40P H8.6 TAPING PRODUCT

DESIGN REVISION NO. 1