

- NOTE -

- 1. TOLERANCE: ±0.2, ANGLE ±3°
- 2. CONPLANARITY: 0.1 MAX
- 3. PART CODE

MG 6 5 5 6 5 4

PART NO.
PLUG ASS'Y

- 4. "6 hazardous substances in parts (Lead, Mercury, Cadmium, Hexavalent Chromium, PBBs, PBDEs) shall not exceed the maximum permissible concentration prescribed under EU ELV Directive & RoHS Regulation."
- 5. No Twist
- 6. Spec : ES91500-03
- 7. Solder : Reflow Solder Only(Surface mount)

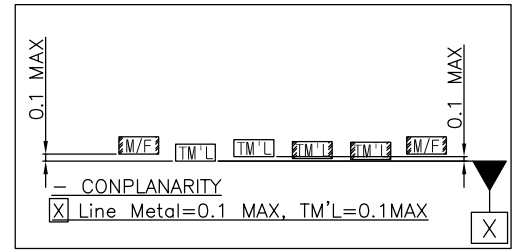
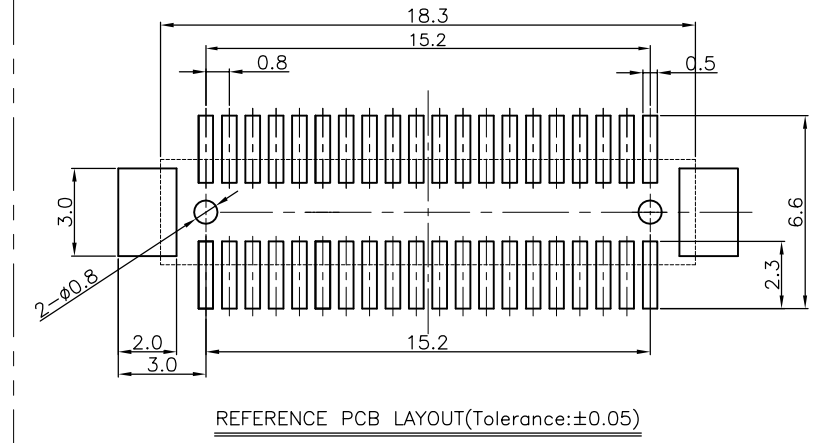

한국전자공업주식회사 출 2012.09.12 도 가 발 행	
DIE NO	ISSUE MARK

4	PLUG HS'G COVER 40P	Polyamide	UL94-V0, BLACK	1				
3	METAL-FITTING	Copper Alloy	Ni1.27~3um+Sn2-5um MAX	2				
2	PLUG H3.7 TM'L	Copper Alloy	Ni1.27~3um+Au 0.1um MAX(Contact) & Au0.03um MIN(Lead)	40				
1	PLUG HS'G 40P H3.7	Polyamide	UL94-V0, BLACK	1				
NO.	NAME	MATERIAL	FINISH	Q'TC				
			MATERIAL -	KET KOREA ELECTRIC [ENGINEERED] TERMINAL CO., LTD.				
			FINISH -					
			WIRE RANGE -					
			INSULATION -					
			CLASS BOARD TO BOARD					
			TYPE FLOATING P=0.8mm					
LTR	REVISION RECORD	DR	CHK	APP	DATE	TOLERANCE EXCEPT AS NOTED	SCALE	PART NO.
		DR. Kim.J.M '12.01.06	CHK. Lee.J.H '12.01.06	APP. Baek.W.C '12.01.06		-	1/1	MG655654
PART NAME B TO B PLUG 40P H3.7 ASS'Y								1/1

DESIGN REVISION NO. 1

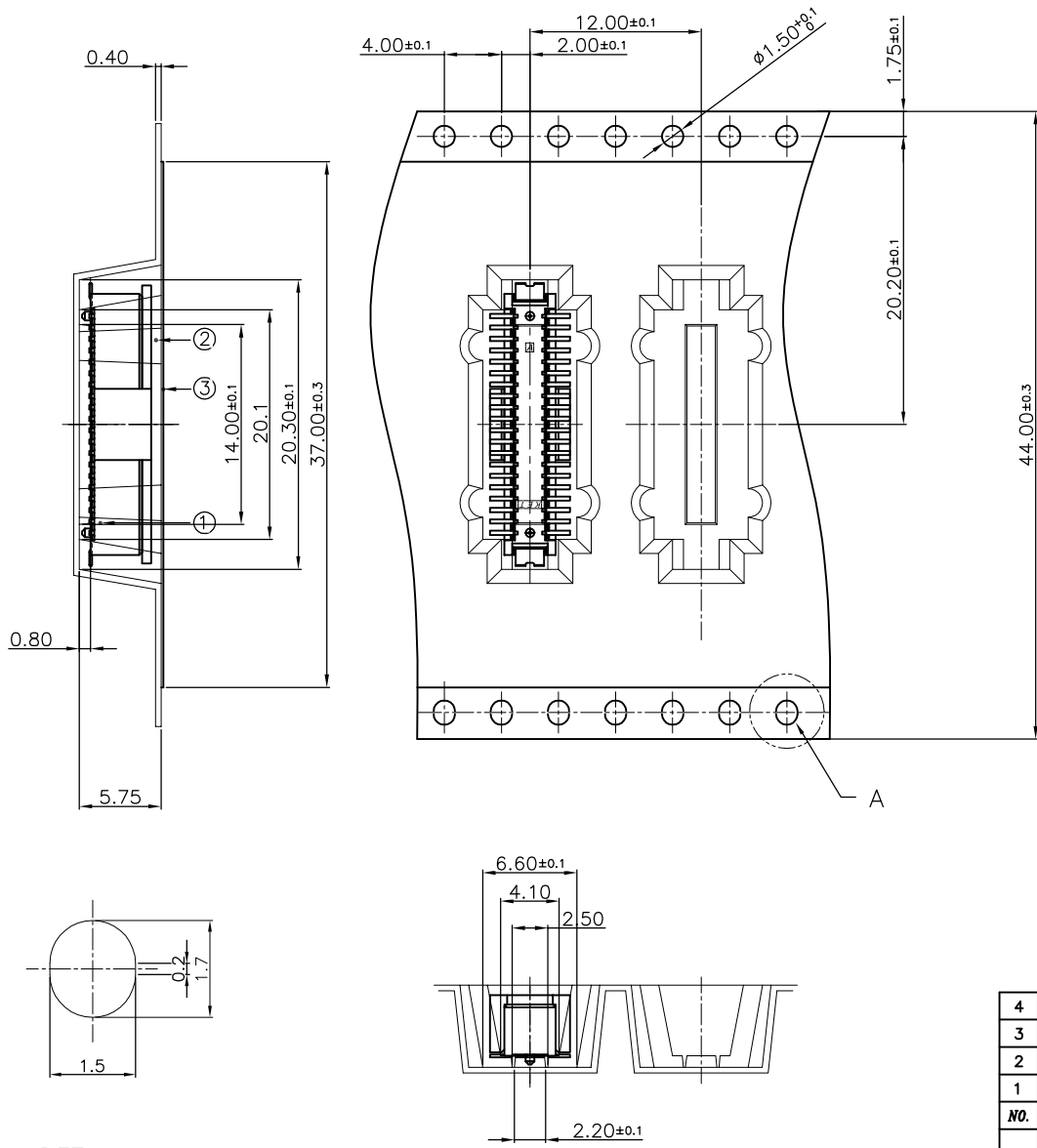

- NOTE -

- 1. NUMBER OF CONNECTOR: 1,500PCS/REEL
- 2. LEAD TAPE LENGTH(mm)
- 3. PEELING OFF FORCE OF TOP TAPE: 0.1N - 0.7N(10.2 - 71.4gf)
PEELING OFF SPEED: 300mm/Min

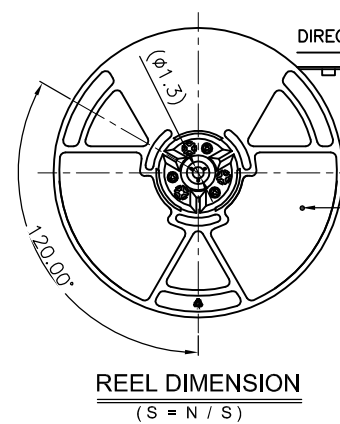
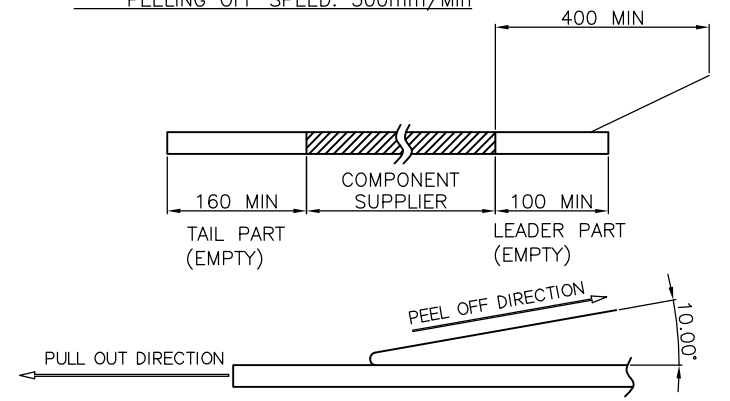

한국전자공업주식회사 출 2012.09.12 도 가 발 행	
300036	ISSUE MARK
TOOL NO	ISSUE MARK

4	REEL	PS	BLACK & BLUE	-	1			
3	COVER TAPE	PET	-	-	-			
2	CARRIER TAPE	PET 0.4t	-	-	-			
1	PLUG 40P H3.7 ASS'Y	-	-	MG655654	1,500			
NO.	NAME	MATERIAL	FINISH	PART NO.	Q'TC			
			MATERIAL -	KET KOREA ELECTRIC [ENGINEERED] TERMINAL CO., LTD.				
			FINISH -					
			WIRE RANGE -					
			INSULATION -					
			CLASS BOARD TO BOARD					
			TYPE FLOATING P=0.8mm					
LTR	REVISION RECORD	DR	CHK	APP	DATE	TOLERANCE EXCEPT AS NOTED	SCALE	PART NO.
		DR. Kim.J.M 12.01.06	CHK. Lee.J.H 12.01.06	APP. B.W.C 12.01.06		-	1/2	P300036
PART NAME B TO B PLUG 40P H3.7 TAPING PRODUCT								1/1

DESIGN REVISION NO. 0